

JMA-3300 Radar



– JRC's new radar incorporates the latest leading technologies

10.4-inch ultra bright LCD
New System-on-Chip technology
Semi-Constaview™ digital signal processing
AIS and MARPA+™ as standard
Newly designed multi-speed scanners

Features

Features

The JMA-3300 series is JRC's newest radar, featuring a 10.4-inch ultra bright LCD, and incorporates the latest digital signal processing for excellent target identification and detection in a compact design.

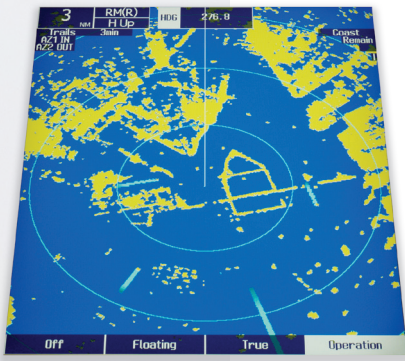

Ultra bright display

The tough glass bonded LCD is backlit by white LED's giving 1000cd/m² of brightness, making the radar image amazingly sharp. Bonding is a process whereby the air gap between the front glass and LCD module is filled with a special compound, significantly enhancing sunlight reflection, night vision and overheating as well as a reduction of possible condensation. This is a feature not previously found on this class of radar.

System-on-Chip

JRC engineers custom designed the System-on-Chip (SoC) inside the new JMA-3300 series to be an extremely powerful tool.

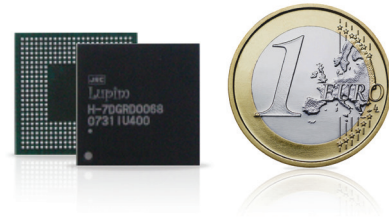

With such a small chip, weighing less than a sugar cube, performance remains at our high standards. At the same time, the SoC technology makes the compact radar very power efficient.

AIS & MARPA+™

The new radar has the ability to display 50 AIS symbols, and 10 MARPA™ tracking targets as standard. The high quality of the display provides outstanding target definition and discrimination.

The (second generation) MARPA™ continues JRC's successful MARPA™ technology first found in the previous JMA-2300 radar series. Our engineers continued developing and improving the technology, until now, with MARPA™, manual or automatic target tracking is even more reliable.

DirecTrak™

The new radar has an easy vessel searching function based on AIS, called DirecTrak™. This function shows the nearest 50 vessels received by the AIS. If you select a vessel on the list, then range and bearing is displayed of the selected vessel.

Operation

Simple operation

Smooth and comfortable operation is guaranteed with the solid and responsive feel of the keys. A dedicated jog-dial is conveniently integrated as well as the function keys for one-touch access to GAIN, SEA and RAIN. The JMA-3300 also incorporates 4 soft-key switches just below the display that can be assigned by the user. Here you can specify commonly used functions, making it even simpler to navigate.



Cursor keys

Range up and down

One-touch access to GAIN, SEA and RAIN

Jog dial

USB memory

Soft keys

Soft keys

The display unit incorporates 4 soft keys, just below the display corresponding to the most used functions of a specific operation using the multi key. You instantly see the options you have, without losing the sight of the radar picture.

Semi-Constaview™

Based on JRC's patented technology found in the bigger radars, the new JMA-3300 integrates Semi-Constaview™. This allows fast processing of targets, showing true trails in Head-Up mode, without interference of fixed targets, such as land or mass.

Sea trials

With Mount Fuji in the background, JRC engineers successfully tested the new JMA-3300 radar in Suruga Bay. See on the right side actual photos results of our SoC technology. Land echoes are clearly visible and smaller echoes are far more enlarged than bigger echoes, giving a better on-screen separation and identification.

USB

Updating your radar with the latest software is made easy with a conveniently integrated USB port on the front side of the display.

Without SoC processing

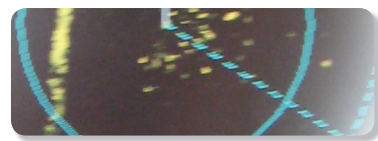

With SoC processing

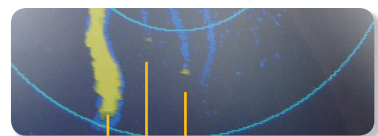

Clear land echo

Jet ski

Small boat

Flexibility

New scanners

With this new radar, JRC introduces 2 new scanners, available in a 4 kW radome and a 6 kW open array configuration, designed in line with our common interface technology found in the bigger radars.

The scanners feature a new high rate PRF¹ which allows for a highly accurate short range detection. Also both integrate the possibility to select the rotation speed, allowing for better discrimination and target detection in busy shipping lanes.

Processor built-in

Besides the display and operating keys, this compact all-in-one unit has the processor integrated, allowing for a flexible installation approach.



Transparent menus

With the transparent (pop-up) windows, you can navigate through menus or view required data, such as own ship data or cursor data, without losing the complete radar image.

Languages

The JMA-3300 series allows you to switch between English, Japanese, French, German, Spanish, Italian, Portuguese and Norwegian.

Trails

Other ship's movement and speed can be monitored from length and direction of their trails, primarily serving for collision avoidance. It integrates four different trail length modes, which will show a ship's course instantly, a unique operational feature that allows for more flexibility.

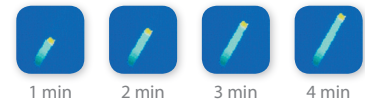

In the box

- Display+bracket+cover
- Scanner
- Scanner cable (20 m)
- Power cable (5 m)
- Various connectors
- Spare parts
- Operation guide
- Manuals

Options

- Rectifier NBA-5111
- VGA output board NQA-2400
- Scanner cable (5/10/15/20/30 m) CFQ-6912-5/10/15/20/30
- Cable for JLR-10 CFQ-6934
- Cable for JLR-20/21/30/31 CFQ-5469
- Cable for NDW-51 CFQ-7082
- NSK unit NCT-4106A
- Simulator NDW-51
- Sun cover MTV304869

Standard scope of supply may vary region by region.



4 KW, 16-48 rpm NKE-2043



6 KW, 16-27 rpm NKE-2063

Weight and dimensions

Display

NCD-2182 Weight 5 kg

Cutout dimensions

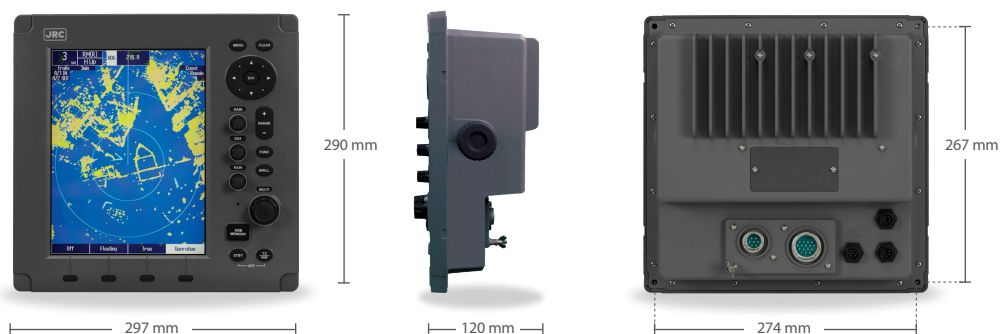

4 kW scanner

NKE-2043 Weight 10 kg



6 kW scanner

NKE-2063 Weight 21 kg



10 kW scanner

NKE-2103-4/6 Weight 34/36 kg

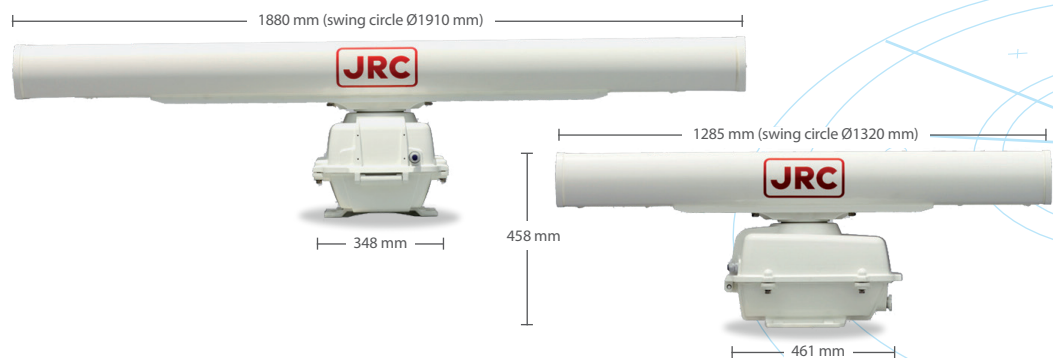

Specifications

JMA-	NEW 3334	NEW 3336	NEW 3336-HS	3340-4	3340-4HS	3340-6	3340-6HS
RoHS	✓	✓	✓	✓	✓	✓	✓
Display type	Raster scan PPI (150mm)						
Antenna length	2 ft	3.9 ft		4 ft		6 ft	
Output power	4 kW	6 kW		10 kW			
Transmitting frequency	9410MHz ±30MHz (X-band)						
Beam width	H:4° V:25°	H:2° V:30°		H:1.8° V:20°		H:1.2° V:20°	
Rotation speed (rpm)	16-48	16-27	27-48	16-27	16-48	16-27	16-48
Pulse width	0.08µs/4000Hz 0.08µs/2500Hz 0.13µs/1700Hz 0.25µs/1700Hz 0.5µs/1200Hz 0.8µs/750Hz 1.0µs/650Hz			0.08µs/2250Hz 0.25µs/1700Hz 0.5µs/1200Hz 0.8µs/750Hz 1.0µs/650Hz			
Range scale ¹	0.125, 0.25, 0.5, 0.75, 1.5, 3, 6, 12, 24, 48, 72 NM						
Display	Glass bonded 10.4-inch LCD display (640 by 480 pixels) 1000cd/m2 by white LED backlit						
Presentation mode ²	RM = North/Head/Course-up, TM = North/Course-up						
Alarms	CPA/TCPA, new target, lost, system error						
MARPA+™ targets ²	10 built-in						
MARPA+™ tracking ²	Up to 20 NM						
MARPA+™ info ²	To be selected from true heading, distance, COG, SOG, CPA, TCPA						
AIS targets ²	50 built-in						
AIS info ²	To be selected from MMSI, call sign, ship's name, COG, SOG, CPA, TCPA, heading, LAT/LON etc						
Input	GGA, RMC, GNS, GLL, RMC, VTG, VBW, VHW, NSK data, DPT, DBT, MTW, ROT, RSA, VDM, VDO, ALR, MWV, VWT, VWR (navigation) THS, HDT, HDG, HDM (bearing) VBW, VHW (speed)						
Output ³	RSD, OSD, TTM, TLL, TTD, GGA, RMC, GNS, GLL, VTG, THS, HDT, ext. buzzer, ext. monitor						
Power	12-24V DC ⁴			24V DC			
Consumption at maximum windload	60W	85W 180W	85W 230W	100W 360W			
Ambient conditions	Temperature: -25° to 55°C (scanner), -15° to 55°C (display) Relative humidity: 0% to 93% non-condensing IP protection rating: IP26 (scanner), IP55 (display)						

1. 4 kW up to 48 NM, 6/10 kW up to 72 NM
2. Data from other equipment required
3. Optional interface may be required
4. Maximum cable length 20 m when 12 V is fed

JRC offices around the world

Authorized reseller

Amsterdam	Hanoi	Manilla	Seattle	Taipei	jrceurope.com
Athens	Hong Kong	New York	Shanghai	Tokyo	
Hamburg	Jakarta	Rio de Janeiro	Singapore		