

Anemometer AM706

Operation & Installation Manual



NINGLU
Website: www.ninglutech.com

Document: NLT-AM706-SSEN
Edition: V190708

***** Quick Operating Guide *****

- **[Mode] : Relative speed/direction + True speed/direction mode and Relative speed/direction + Max speed + Average speed mode**
- **[MENU] : Set Wind Alarm, Speed Unit, Avg Time, Input Show, Language, Back Color and Dig Color.**
- **Calibration : After finishing the main unit AM706E installation and power on, hold the wind vane to the direction of the bow line, then push the button in the junction box.**

Contents

Introduction	1
System Composition	1
Main Unit AM706E	1
Sensor unit AM706S	1
Principle of Measurement	2
Function and Operation	3
Display Layout.....	3
Function.....	3
Power on/off.....	3
Brightness	3
OK.....	4
Day/Night Mode	4
MODE	4
Arrow Keys.....	5
MENU	5
Wind Alarm	5
Speed Unit.....	6
Avg Time	6
Input Show.....	6
Language.....	7
Back Color.....	7
Dig Color.....	7
Default	7
Send True.....	7
Data transmission for NMEA0183	8
Main Unit Output --MWV	8
GPS Data Input--RMC	8
GPS Data Input--VTG.....	9
Speedlog Data Input--VBW	9
Speedlog Data Input--VHW	10
Gyro Data Input--HDT.....	10
Specification	11
Basic Specification	11
Environmental Conditions	11
Technical Specification.....	12
Maintenance	13
Main Unit	13
Sensor Part	13
Calibration	14
Installation	15
Installation of Main Unit AM706E	15
Power Adapter Installation	16
Installation of Wind sensor AM706S	17
Wind Vane and Wind Cup Installation.....	17
Integral Installation.....	18
Wiring Explanation	19
System View.....	19
Wiring Diagram of AM706E Back Cover.....	20
System External Wiring Diagram.....	21

Introduction

The Marine Anemometer AM706 is a combined instrument for wind speed and direction. It can measure relative wind speed (accuracy $\pm 5\%$, min 0.1m/s), relative wind direction (digital display accuracy 1° , analog display accuracy 10° and output accuracy $\pm 1^\circ$). GYRO (HDT), SPEEDLOG (VBW) or GPS (RMC/VTG) data user can select relative wind mode and true wind mode.

Main unit AM706E can be installed by the table, hanging and flush mounting methods. Sensor AM706S should be installed in the place with free wind in the ship.

System Composition

Main Unit AM706E

Direction Display: Analog and digital display of relative (to the bow) and true wind direction

Speed Display: Digital display of relative, true, max and average wind speed.

Sensor unit AM706S

Wind speed sensor: Wind speed sensor has a rotor with three wind cups.

Wind direction sensor: Wind direction sensor has a wind vane to drive an absolute angle sensor unit.

Holder: Used to install wind speed sensor and direction sensor for fixation of junction box

Junction box: Consist of waterproof junction box and sensor unit transmitter.

Introduction

Principle of Measurement

The wind speed sensor has a rotor with three wind cups which spins as the wind moves past the boat. The Wind speed sensor measures how fast the rotor is spinning to calculate the wind speed. The wind direction sensor has a wind vane which points in the direction that the wind is coming from. The wind direction sensor electronically senses the direction the wind vane is pointing. With inputting GYRO (HDT) , SPEEDLOG (VBW) or GPS (RMC/VTG) data, calculate and display the true wind speed and direction (relative to north pole) .

Function and Operation

Display Layout

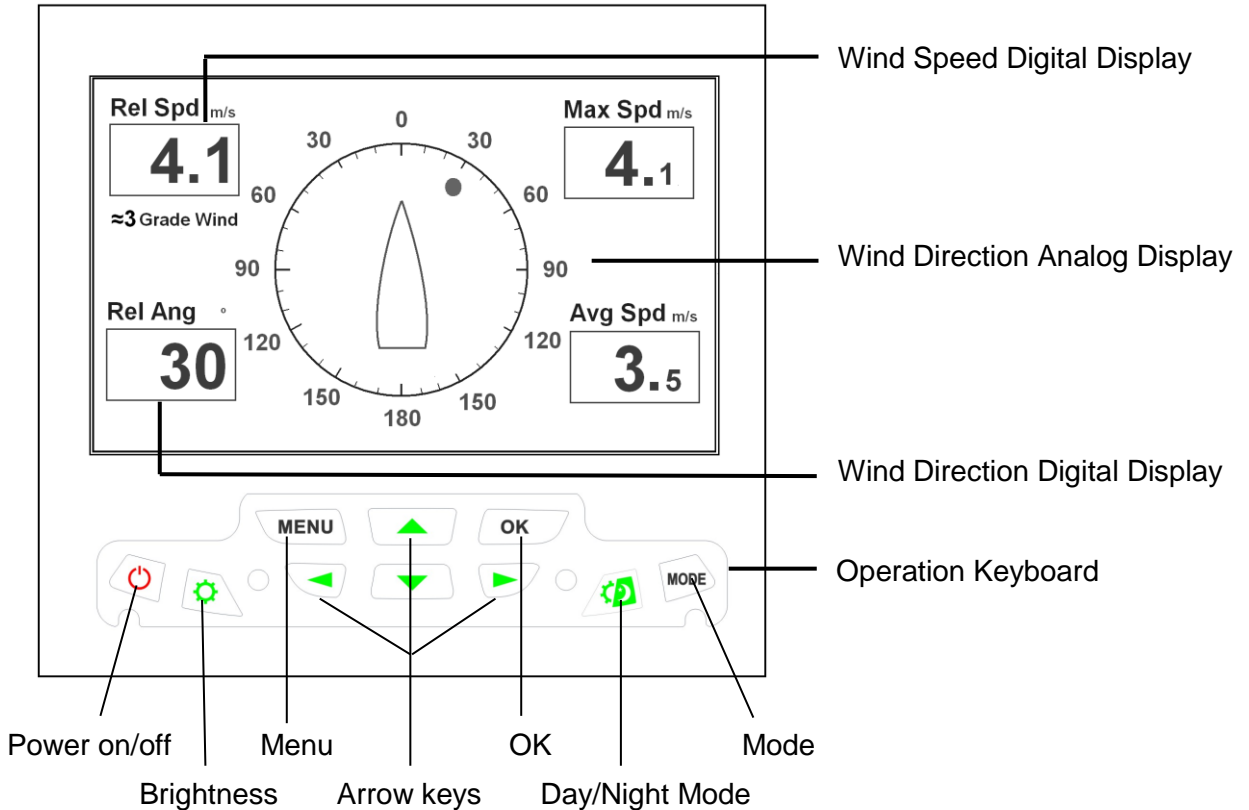

Function

Power on/off

Press the on-off key to turn on /off the system.

Brightness

In Day/Night mode, press the brightness key to adjust the screen brightness.

There are 9 levels for selection.

Function and Operation

OK

Press [OK] key to save the settings in the menu and return to the main screen.

Day/Night Mode

Press the Day/Night mode key to switch the day mode and night mode.

MODE

Press [MODE] key to select Relative Mode (relative speed + relative angle + max speed + average speed) and True Mode (relative speed + relative angle + true speed + true Angle).

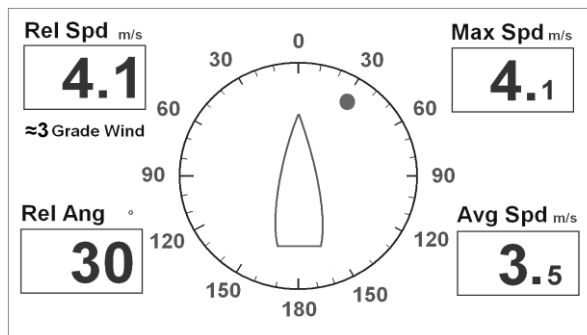

Relative Mode

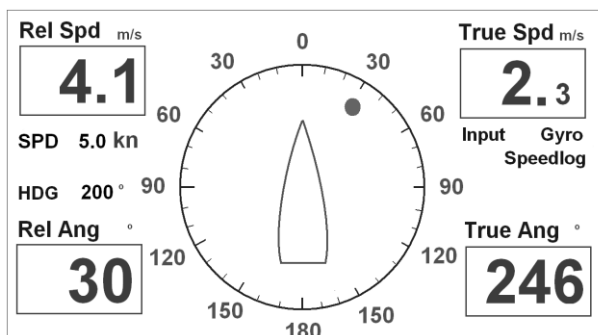

True Mode

Note: The wind grade (see Appendix) can only be shown in relative mode.

The ship speed and heading can be only shown in true mode.

Function and Operation

Arrow Keys

In the menu mode, press up/down arrow keys to select the setting items and press left/right arrow keys to select the setting values.

MENU

Menu Explanation

Item	Range	Default
Wind Alarm	[Off 1~60m/s]	Off
Speed Unit	[m/s km/h knots]	m/s
Avg Time	[1 min 2 min 5 min 10 min]	10 min
Input Show	[Off On]	Off
Language	[English 中文]	English
Back Color	[Light-Blue Blue Black]	Light-Blue
Dig Color	[Yellow in Blue Green in Black White in Black]	Yellow in Blue
Default	[Off Reset]	Off
Send Ture	[Yes No]	No

Wind Alarm

Set the relative wind speed alarm values. When the relative wind speed is larger than the relative wind alarm value, the system will give the alarm signal after 30s with beep and speed numbers become red color and flash. Press any key to mute the beep but the relative speed numbers are still in red color and flash. When the relative wind speed is less than the relative wind alarm

Function and Operation

value, the relative speed numbers return to white color and not flash. Then the system will be working normally.

Press up/down arrow keys to select the item 'Wind Alarm' and press left/right arrow keys to set the wind alarm values.

Setting Range is 1~60m/s and default is Off

Speed Unit

Set the wind speed unit. Press up/down arrow keys to select the item 'Speed Unit' and press left/right arrow keys to select speed unit.

1~60m/s and default is Off

Setting Range is m/s, km/h and knots and default is m/s.

Avg Time

Set the computing period of the max speed and average speed. Press up/down arrow keys to select the item 'Avg Time' and press left/right arrow keys to set the period.

Setting Range is 1 min, 2 min, 5 min and 10 min and default is 10 min.

Input Show

Set the input display of Gyro, Speedlog and GPS. Press up/down arrow keys to select the item 'Input Show' and press left/right arrow keys to select on and off.

Setting Range is Off and On and default is Off.

Function and Operation

Language

Set the system language. Press up/down arrow keys to select the item 'Language' and press left/right arrow keys to select English and Chinese.

Setting Range is English and 中文 and default is English.

Back Color

Set the background color. Press up/down arrow keys to select the item 'Back Color' and press left/right arrow keys to select the colors.

Setting Range is Light-Blue, Blue and Black and default is Light-Blue.

Dig Color

Set the window and number colors. Press up/down arrow keys to select the item 'Dig Color' and press left/right arrow keys to select the colors.

Setting Range is Yellow in Blue, Green in Black and White in Black and default is Yellow in Blue.

Default

Reset the system. Setting Range is Off and Reset, and default is Off.

Send Ture

Set the transmitted relative or true sentence. Yes is to transmit relative and true sentence and No is to transmit relative sentence.

Function and Operation

Data transmission for NMEA0183

Main Unit Output --MWV

\$--MWV, x.x , a , x.x , a , A*hh<CR><LF>

1	2	3	4	5	6
---	---	---	---	---	---

- 1) Wind angle, 0 to 359 degrees
- 2) Reference, R = Relative, T = True
- 3) Wind Speed
- 4) Wind Speed Units, K=km/h / M=m/s / N=knots
- 5) Status, A = Data Valid, V = Data invalid
- 6) Checksum

GPS Data Input--RMC

\$--RMC, hhmmss.ss,A,llll.ll,a,yyyyy.yy,a,x.x,x.x,xxxxxx,x.x,a,a*hh<CR><LF>

1	2	3	4	5	6	7	8	9	10
---	---	---	---	---	---	---	---	---	----

- 1) UTC Time
- 2) Status, A=Data valid, V = Navigation receiver warning
- 3) Latitude, N or S
- 4) Longitude, E or W
- 5) Speed over ground, knots
- 6) Course Over Ground, degrees true
- 7) Date: ddmmyy
- 8) Magnetic Variation, degrees, E or W
- 9) Mode Indicator
- 10) Checksum

Function and Operation

GPS Data Input--VTG

\$--VTG, x.x,T , x.x,M , x.x,N , x.x,K , a*hh<CR><LF>

1 2 3 4 5 6

- (1) Course over ground, degree true
- (2) Course over ground, degree magnetic
- (3) Speed over ground, knots
- (4) Speed over ground, km/h
- (5) Mode indicator, A=Autonomous mode
 D=Differential mode
 E=Estimated (dead reckoning) mode
 M=Manual input mode
 S=Simulator mode
 N=Data not valid
- (6) Checksum value

Speedlog Data Input--VBW

\$--VBW, x.x , x.x , A , x.x , x.x , A , x.x , A , x.x , A*hh<CR><LF>

1 2 3 4 5 6 7 8 9 10 11

- (1) Longitudinal water speed, Knots
- (2) Transverse water speed, Knots
- (3) Status: water speed, A=data valid, V=data invalid
- (4) Longitudinal ground speed, Knots
- (5) Transverse ground speed, Knots
- (6) Status: ground speed, A=data valid, V=data invalid
- (7) Stern transverse water speed, Knots
- (8) Status: stern water speed, A=data valid, V=data invalid
- (9) Stern transverse ground speed, Knots
- (10) Status: stern ground speed, A=data valid, V=data invalid
- (11) Checksum value

Function and Operation

Speedlog Data Input--VHW

\$--VHW, x.x₁, T, x.x₂, M, x.x₃, N, x.x₄, K*hh<CR><LF>

- (1) Heading, degrees True
- (2) Heading, degrees Magnetic
- (3) Speed, knots
- (4) Speed, km/hr

Gyro Data Input--HDT

\$--HDT, x.x₁, T₂, * hh₃<CR><LF>

- (1) Heading, degree true
- (2) T = true
- (3) Checksum value

Specification

Basic Specification

Main Unit Dimension (AM706E) :	W188mm	H166mm	D65 mm
Weight:	Main Unit	2kg	Sensor 10kg
Power Supply:	Main Unit	DC24V (DC20-32V)	
	Sensor	DC11-36V (0.15A@DC24V)	
Power through adapter:	110/220V	50/60Hz	AC
Power:	< 5W	(24V DC)	
NMEA Input Baud Rate:	4800bps	(9600 bps for GPS data input)	
Wind Output Baud Rate:	4800bps		
Data Input:	RS422 and NMEA0183	Standard	
Sensor Dimension (AM706S) :	H838mm	Activity Radius	550 mm

Environmental Conditions

Working Temperature:	Main Unit	-20°C~+55°C
	Sensor	-20°C~+85°C
Storage Temperature:	Main Unit	-20°C~+70°C
	Sensor	-20°C~+85°C
Humidity:	Main Unit	10%~90% RH
	Sensor	10%~100%RH
Protection:	IP 23	

Specification

Technical Specification

Wind Speed Range:	0~60m/s
Wind Speed Accuracy:	±5% (min0.1m/s)
Wind Direction Range:	0~359°
Wind Direction Accuracy:	±1°
Min Start Speed:	≤1.2m/s

Maintenance

Main Unit

The main unit is maintenance-free.

If doing the cleaning, use soft cloth and mild detergent, and avoid water drop.

Sensor Part

When there is ice or dirt on sensor to disturb the normal work, please clear in time.

Regularly check external mounting bolts to avoid looseness and the abrasion and ageing of cables

When the equipment breaks down, please contact our engineers of after-sale service department in time. Please do not do the service by yourself.

Calibration

Calibration of AM706 wind vane after finishing the installation.

Wind Direction Calibration

风向校准

- ① Press POWER key to turn power on.
按主机上的开关键开机

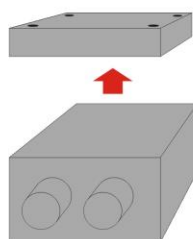
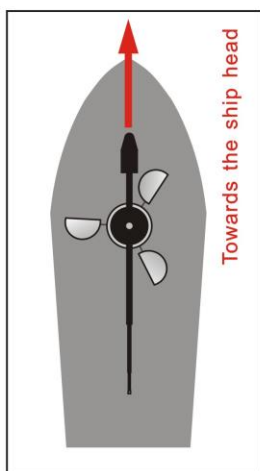

- ② Assistant goes up to hold the vane towards the ship head (Fore direction). And open the waterproof junction box.

请助手爬上桅杆将风向标箭头扶正指向船头(正前方),并打开防水接线盒。



- ③ Press button inside the waterproof junction box, the relative direction towards ship head. Close the box in the end.

风向标指向船头的同时,按下防水接线盒的按钮。
最后关上防水接线盒。

Installation

Installation of Main Unit AM706E

The Main unit AM706E has three mounting methods, table, hanging and flush mounting.

The holder supplied by original factory setting is used in table and hung mounting.

For flushing mounting, embed the main unit into the bridge control panel (the dimension is shown below) and tighten the rotary knob to fix the main unit.

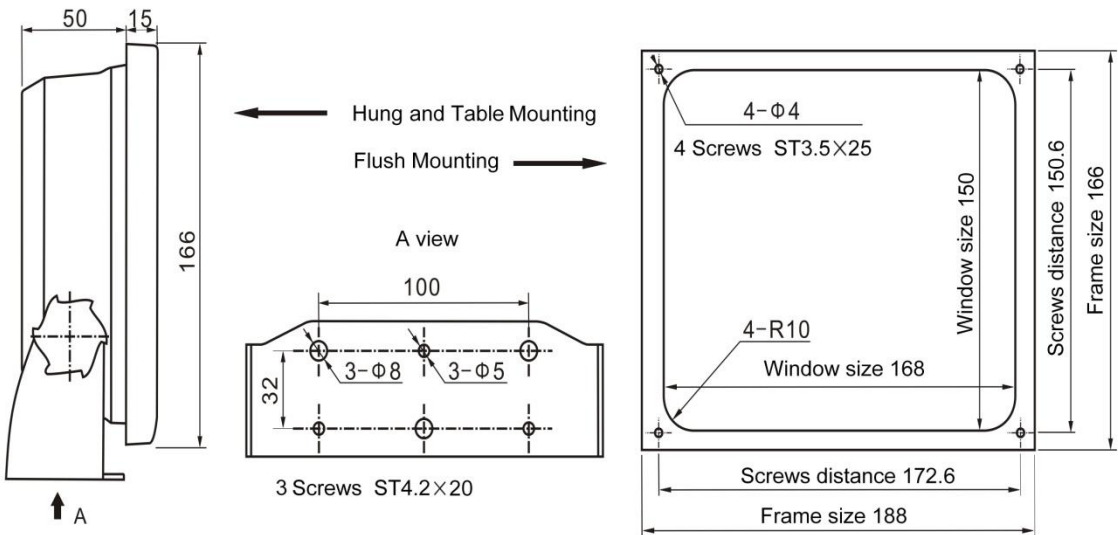

Installation

Power Adapter Installation

Power adapter (GA-240150), AC220/110V to DC24V, adapter holder and screws. Weight: 2.4kg.

Unit: mm

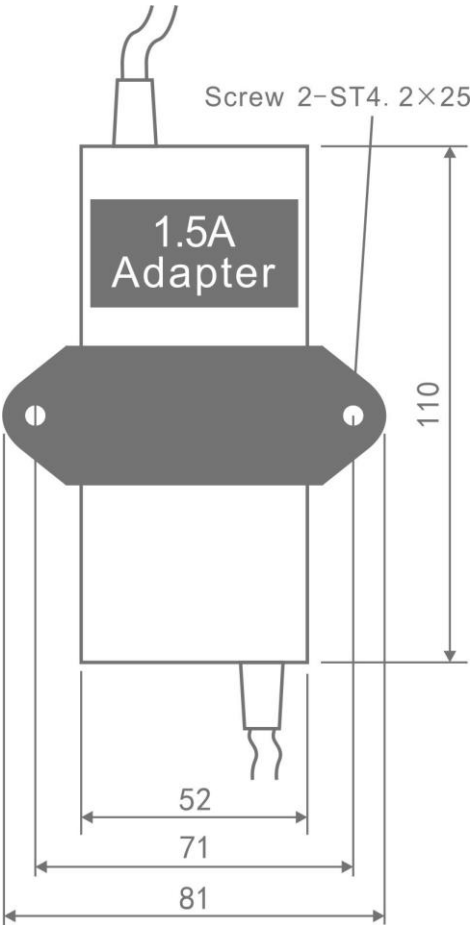

Installation

Installation of Wind sensor AM706S

Wind Vane and Wind Cup Installation

[**Wind Vane**] Wind vane is installed on the top of sensor holder, successively into black seal ring, plane washer, spring washer and 2 screw nuts. The two screw nuts should be tightened and then insert the cotter.

[**Wind Cup**] Wind cup is installed on the bottom of sensor holder, successively into plane washer, spring washer and 2 screw nuts. The two screw nuts should be tightened and then insert the cotter.

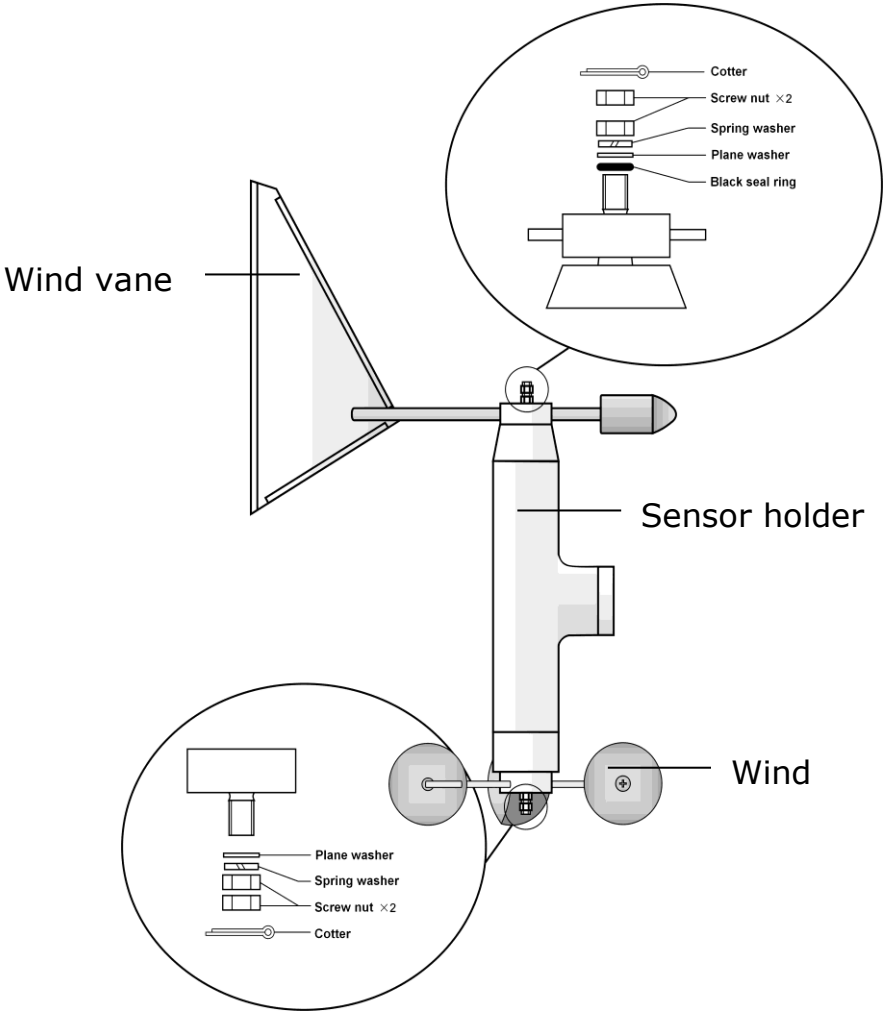

Installation

Integral Installation

[**Space and location**] The total height of wind sensor is 838mm. It should be horizontally installed on the ventilated place of ship and the action radius of wind indicator and wind cup is over 550mm.



Please note, big Radar antenna rotation can disturb the wind measurement. Find a location away from Radar.

[**Integral fixation**] Use U-bolt in the accessory to fix wind sensor and the best option of supporting tube diameter is 60mm.

[**Wiring**] 4-core screened cable with external diameter 4mm~6mm is connected with 4 terminals +、-、B、A through glands of junction box. Please pay attention on wire colors and sequence in order to correctly connect the wiring terminals of back cover, 1+ 2- 3B 4A.

[**Calibration**] After the installation of main unit of wind sensor, do the calibration of wind direction based on Calibration.

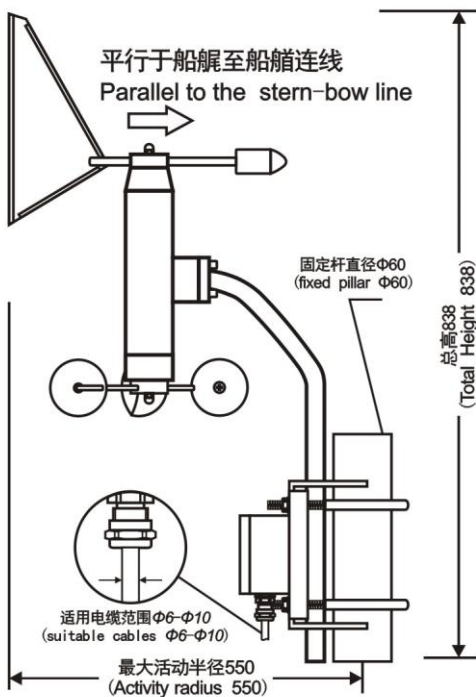

AM706S junction box terminals

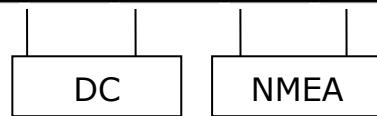
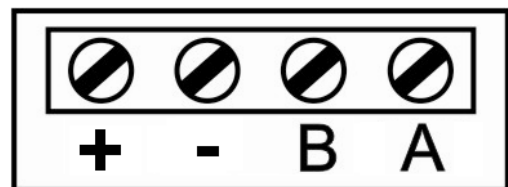

AM706D back cover terminals

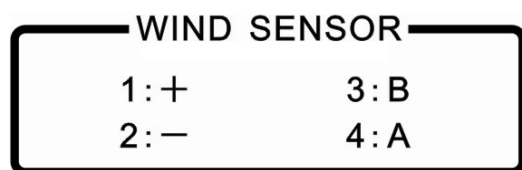

Wiring Explanation

System View

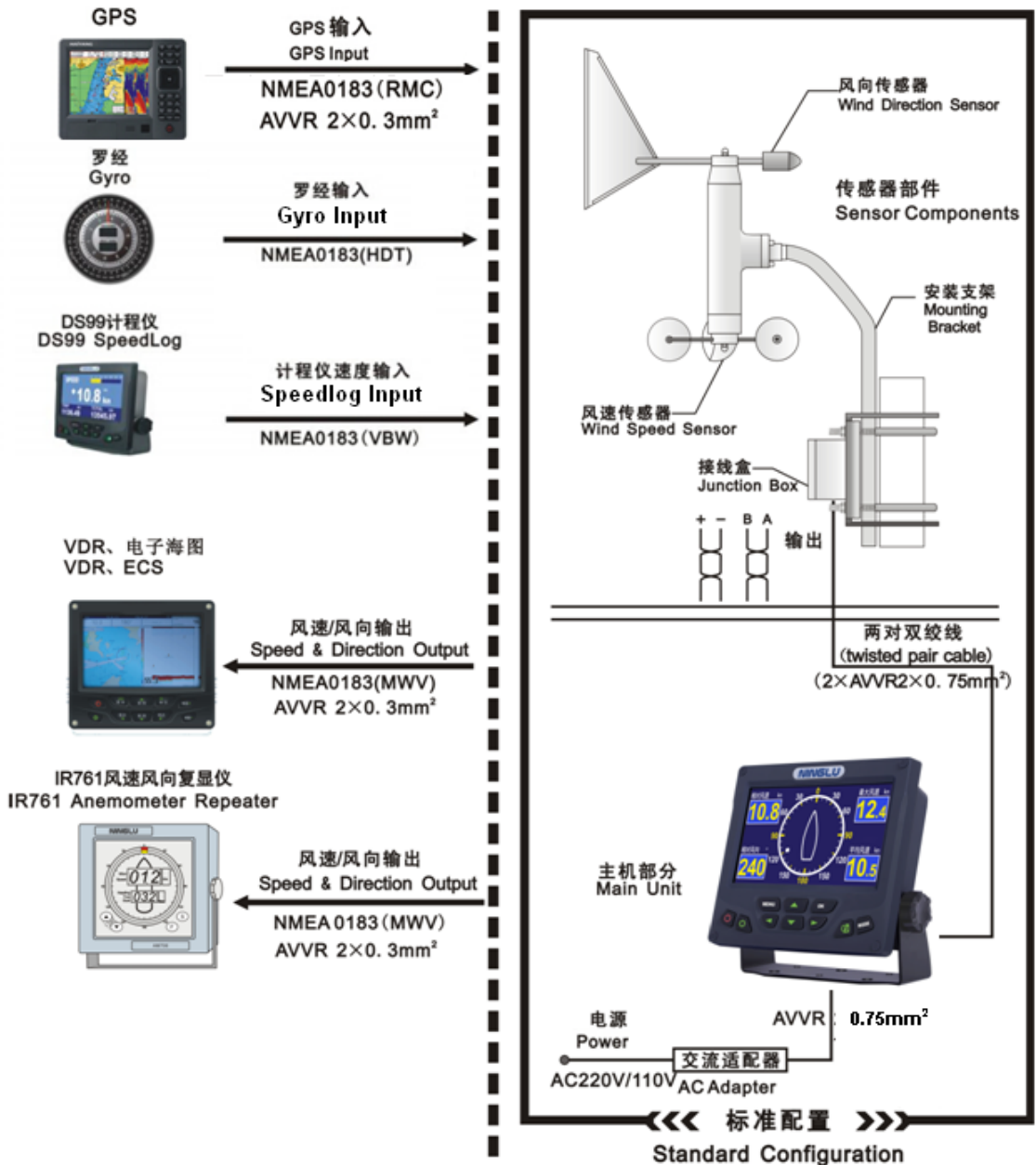

Wiring Explanation

Wiring Diagram of AM706E Back Cover

ANEMOMETER

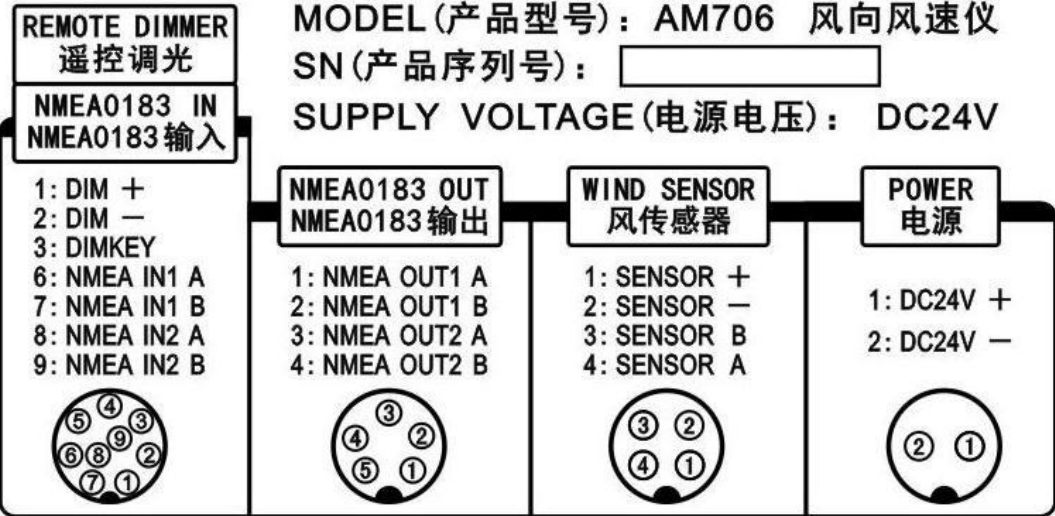

Wiring Explanation

System External Wiring Diagram

AM706E Main Unit Wiring Diagram

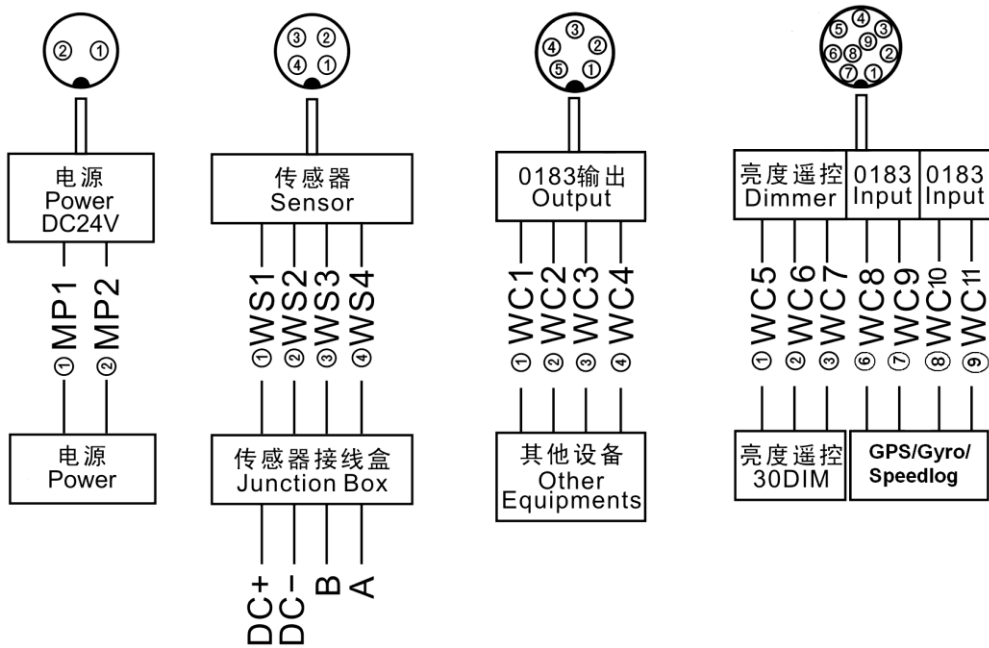

名称 Name	内容 Content	名称 Name	内容 Content
MP1	电源 + Power +	WC1	NMEA 0183输出 1 A NMEA 0183 Output 1 A
MP2	电源 - Power -	WC2	NMEA 0183输出 1 B NMEA 0183 Output 1 B
WS1	传感器电源输出 + Sensor power output +	WC3	NMEA 0183输出 2 A NMEA 0183 Output 2 A
WS2	传感器电源输出 - Sensor power output -	WC4	NMEA 0183输出 2 B NMEA 0183 Output 2 B
WS3	传感器数据输入 B Sensor data input B	WC5	亮度 + DIM +
WS4	传感器数据输入 A Sensor data input A	WC6	亮度 - DIM -
		WC7	亮度公共线 DIMKEY
		WC8	NMEA 0183输入 1 A NMEA 0183 Input 1 A
		WC9	NMEA 0183输入 1 B NMEA 0183 Input 1 B
		WC10	NMEA 0183输入 2 A NMEA 0183 Input 2 A
		WC11	NMEA 0183输入 2 B NMEA 0183 Input 2 B

Appendix

Wind Grade Table

Grade	Speed (m/s)	Speed (km/h)	Grade	Speed (m/s)	Speed (km/h)
0	0.0~0.2	<1	10	24.5~28.4	89~102
1	0.3~1.5	1~5	11	28.5~32.6	103~117
2	1.6~3.3	6~11	12	32.7~36.9	118~133
3	3.4~5.4	12~19	13	37.0~41.4	134~149
4	5.5~7.9	20~28	14	41.5~46.1	150~166
5	8.0~10.7	29~38	15	46.2~50.9	167~183
6	10.8~13.8	39~49	16	51.0~56.0	184~200
7	13.9~17.1	50~61	17	56.1~61.2	202~220
8	17.2~20.7	62~74	>17	≥61.3	≥221
9	20.8~24.4	75~88			