

Synapsis ECDIS

Electronic Chart Display and Information System



Synapsis ECDIS

Enhanced Functionalities for Safe and Comfortable Navigation.

The Raytheon Anschütz Synapsis ECDIS is a high performance Electronic Chart Display and Information System. It provides all needed information and offers helpful functions for the planning and the monitoring of routes which account for the safety at sea and also disburden the ship's command in its long ranged business.

Synapsis ECDIS is based on clear display design, easy-to-operate menu structures and comfortable server functionalities. The comprehensible and intuitive handling is supported by the use of the well-known menu structure of windows applications. Five different ranges of colour make the ECDIS easy to use with respect to all prevalent lighting conditions.

Synapsis ECDIS provides intelligent functions which outrun the basic IMO requirements. The ECDIS offers, in interaction with other bridge navigation systems, effective support for the ship's safe and comfortable navigation

In addition to IHO/IMO compliant vector Electronic Navigation Charts (ENC), Synapsis ECDIS also displays raster charts (ARCS). Synapsis ECDIS complies with latest requirements such as IEC/EN 61174 (Performance Standards for ECDIS), IEC/EN 61162-1, IEC/EN 60945, MED 96/998/EC (Wheelmark) and other relevant standards of IMO, IHO and IEC.

The Raytheon Anschütz worldwide sales and service network ensures qualified product und service support wherever needed at any time.

Chart formats / availability

- C-Map ENC (paper chart equivalence)
- C-Map Professional +
- S 57/S 63 Encrypted ENC
- DNC
- ARCS

ECDIS Standard Display

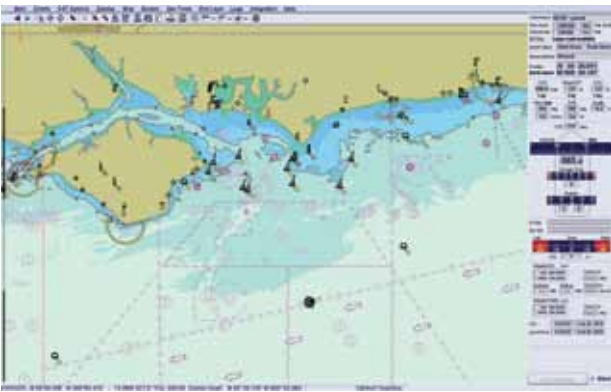

More than 200 service stations all around the world. Our worldwide sales and service network provides product and service support wherever needed.

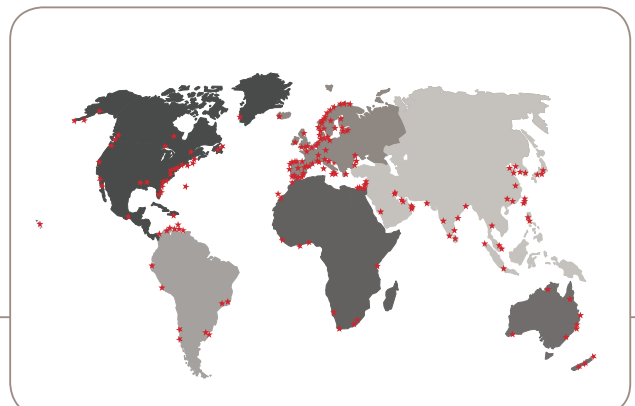

ECDIS Functions

- Automatic selection of navigational charts relative to position with both ENC and ARCS charts
- Selectable information panel with various Conning data
- Chart Server / Route Server: Automatic sharing of charts, updates and routes when the configuration contains more than one ECDIS
- AIS-Server function
- Route planning and graphical display
- Route monitoring and look ahead zones
- Graphic display of heading change manoeuvres
- Display of track data information
- Display of radar information (tracked ARPA targets)
- Recording and output of relevant voyage information (black-box function) in accordance to IMO Performance Standard
- Online help available to support the operator at work
- Available as Desktop, Table Top or Blackbox version – for stand alone installation, installation at top of a console or integration into a customer's console.
- Optional Autopilot Remote Control
- Curved heading line with NautoPilot® NP 5000

Paperless Navigation

The ECDIS is an essential part of a modern Integrated Bridge and Navigation System. The ECDIS is to:

- Increase safety through planning of safe routes and route monitoring
- Enhance overall situation awareness through combination of all voyage related information
- Offer effectively support in decision making for the navigator and simplify watch keeping

To fit out a vessel with two ECDIS offers, depending on the flag state and the area of operation, the benefit of paperless navigation. This means:

- Save money without paper charts
- Save overtime and manual corrections
- Avoid trouble with port state control and delays

NEW:
Online operator training
(acc. to STCW) available.



Own Ship Symbol HiRes Outline

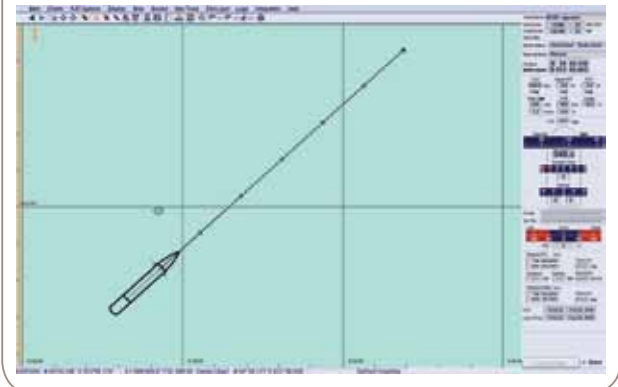

Lookahead Zone

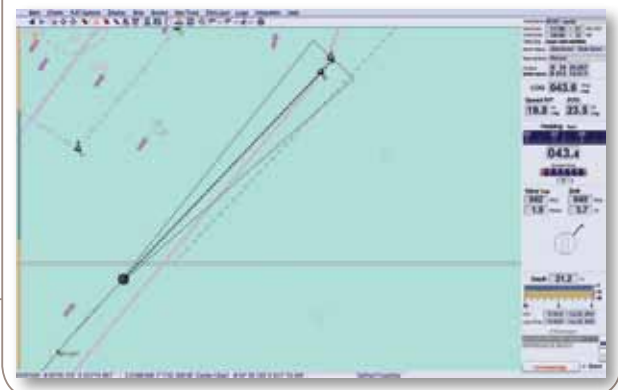

Synapsis ECDIS Advanced Functionality

Ease of Use and Colour Palettes

Synapsis ECDIS features clearly arranged functions within an intuitive to operate HMI. For optimized readability under all prevalent lighting conditions, five different ranges of colour are available to contribute to safe operation.

Online Updating Service

Work and time can be saved by taking advantage of the Synapsis ECDIS online updating service for C-Map charts. Connected to the ship's broadband, the chart update will only take two minutes.

Automatic Route Planning (using C-Map Professional + Database)

The Automatic Route Planning allows saving workload and time. It will only need a handful of click to plan a safe route. Individual settings such as included or excluded sea areas or passages can always be included.

Autopilot Control Function

Autopilot remote control is available to enable the changing the course of the ship while watching the ECDIS screen. On the screen the course change is displayed as a "curved heading line". Immediate override of autopilot is possible.

AIS Target Integration

With an easy-operate toolbar button all relevant AIS information of other vessels can be displayed on the ECDIS. This offers total awareness with only one mouse-click.

AIS Operation and Text Messaging

User inputs such as voyage related data and the navigational status of the own ship can be edited on ECDIS screen. No separate data input on the AIS is necessary.

Navtex Integration

Current Navtex messages can be displayed on the ECDIS screen to further enhance situational awareness. Printing of messages is possible, thus separate Navtex printers are no longer needed.

Tidal Prediction Mode

The ECDIS contains an integrated tidal calendar to display relevant tidal information for various ports round the world.

High Precise Track Control

Precise steering algorithms of Anschütz NautoPilots ensure highest accuracy. It only takes two clicks and the vessel will steer along a pre-planned track automatically. Track Control of Category B is possible with NP 2015 / 2025 / 5100 / 5300; Track Control of Category C is possible with NP 2025 Plus / 2035 / 5400 / 5500.

ECDIS Dusk Colours

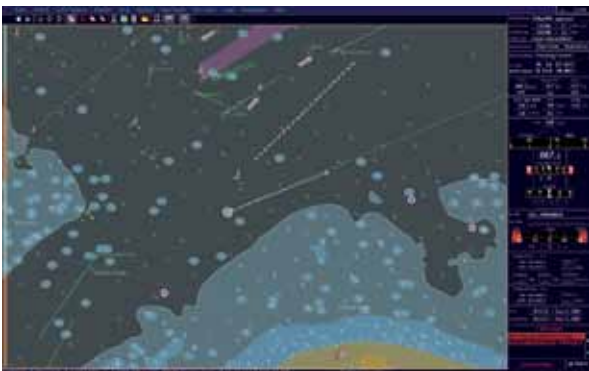

Automatic Route Planning

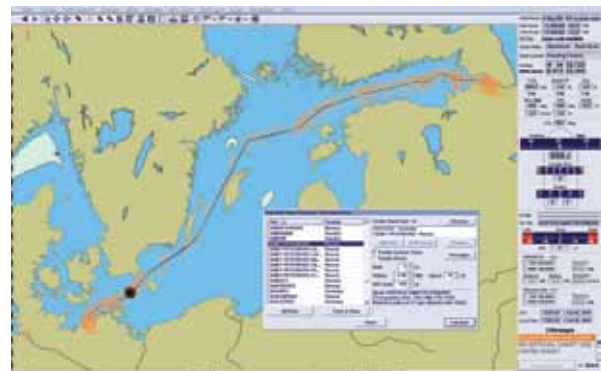

Tender Tracking Function (option)

A Tender Tracking module is available for integration into the ECDIS. Tender boats send encoded signals with navigational data which are processed and displayed on the ECDIS screen.

Weather Overlay (option)

A Synopsis ECDIS allows the integration of current weather information and weather forecast symbols to optimize route and voyage planning with regard to fuel efficiency, avoidance of hull and load damages, sea sickness of passengers and on-time arrivals.

Radar Image Overlay (option)

An overlay of radar video on the ECDIS screen is available to increase safety and efficiency of ship operation. Chart information and radar targets appear in one display with just one mouse-click on a toolbar button.

NavTex

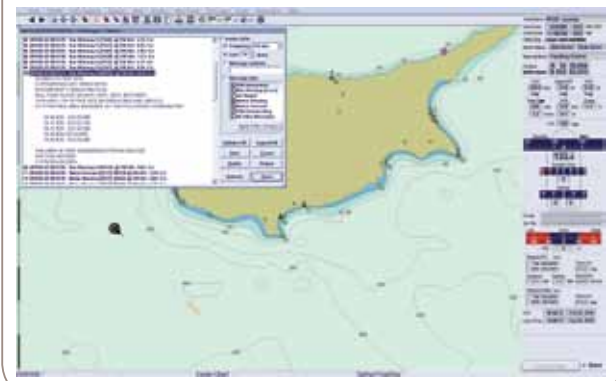

Track Control



AIS Targets and AIS operation



Radar Image Overlay

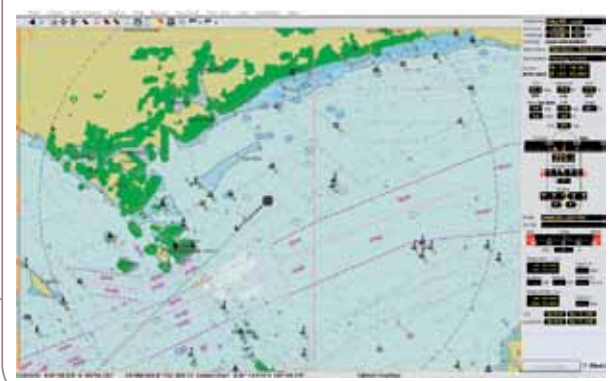

New ECDIS Carriage Requirements

Passenger Ships

Ship size Constructed	Less than 500 gt	500 gt or more
Before 1 July 2012	No ECDIS required!	ECDIS required from 1st survey, latest 1 July 2014
On or after 1 July 2012	No ECDIS required!	ECDIS required from 1 July 2012

Tankers

Ship size Constructed	Less than 3,000 gt	3,000 gt or more
Before 1 July 2012	No ECDIS required!	ECDIS required from 1st survey, latest 1 July 2015
On or after 1 July 2012	No ECDIS required!	ECDIS required from 1 July 2012

Cargo Ships, other than Tankers

Ship size Constructed	Less than 3,000 gt	3,000 gt to 10,000 gt	10,000 gt to 20,000 gt	20,000 gt to 50,000 gt	50,000 gt or more
Before 1 July 2013	No ECDIS required!	No ECDIS required!	ECDIS required from 1st survey, latest 1 July 2018	ECDIS required from 1st survey, latest 1 July 2017	ECDIS required from 1st survey, latest 1 July 2016
On or after 1 July 2013	No ECDIS required!	No ECDIS required!	ECDIS required from 1 July 2013	ECDIS required from 1 July 2013	ECDIS required from 1 July 2013
On or after 1 July 2014	No ECDIS required!	ECDIS required from 1 July 2014	ECDIS required, see above	ECDIS required, see above	ECDIS required, see above

System Integration

Synopsis ECDIS interfaces with many existing bridge systems and navigation equipment. It can be configured for integration with ARPA radar, autopilot, AIS, echo sounder, speed log, wind speed direction sensor, position receivers and engine rpm sensors. Thus Synopsis ECDIS is able to display navigational sensor data and corresponding alarms.

- AIS (Automatic Identification System) Display of AIS targets, additional information to provide a better overview of traffic situation
- ECDIS/GPS Display route coming from ECDIS/GPS
- ARCP-Panel (Autopilot Remote Control Panel) Autopilot operation directly from radar workplace

- SENC-Data (System Electronic Navigation Chart-Data) Input of selected chart symbols from Raytheon Anschütz ECDIS
- Synopsis Conning
- LAN

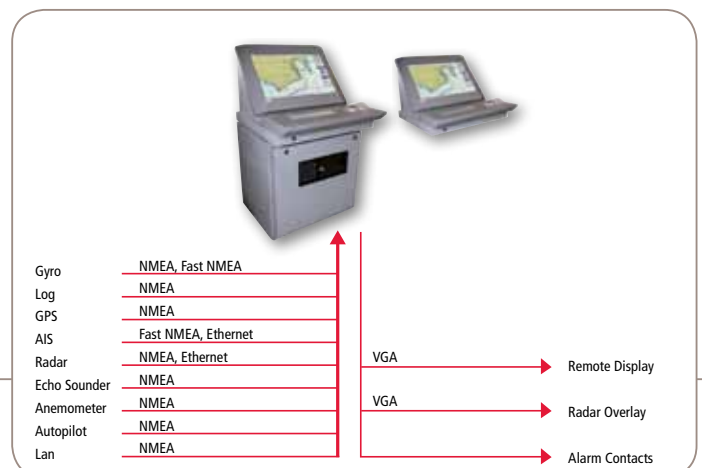

Conning Compact

Being an alternative to a full Conning display, Raytheon Anschütz offers a Conning Compact solution as an accessory of Synapsis ECDIS. A separate TFT flat screen display statically offers all relevant navigation data such as heading, position, rudder, speed, depth, wind or track data at a glance, contributing to increased awareness of the specific navigation situation within a cost-effective solution. All data and information are shared with ECDIS, requiring only a single wire connection.

Conning Compact Display with Dual Rudder



Multifunction Workstation

Synapsis ECDIS uses the new standardized, ultra-compact Synapsis PC with solid-state disk and passive cooling instead of a fan, that was designed to increase reliability. The ECDIS is available as an independent stand-alone system or as part of a Multifunction Workstation in combination with type-approved (Chart-) Radar and Conning. These functionalities run in parallel on one processor, the selection is possible by a pull-down menu at the right corner of the screen. To have all data visible at a glance reduces stress during watch-keeping and ensures that the navigator can concentrate on main tasks especially in demanding situations. Tailor-made solutions assist the crew in route planning, collision avoidance and track control and therefore enhance navigational safety.



Technical Data

Basic Equipment

Monitor

- High resolution TFT-Display,
- Resolution 19": 1280x1024 pixel,
- Resolution 26": 1920x1200 pixel

PC Work Station with

- Intel® microprocessor
- Operating system: Windows 2000™ Windows XP™ SP3
- Interface PCB: serial Multi-IO board,
- DVD ROM drive
- VGA video output to additional remote display

Options

- Remote trackball
- Radar overlay
- Autopilot remote control panel
- System integration via Ethernet

System safety

- Uninterrupted power supply (UPS)

Synapsis ECDIS w/26" TFT Deckstand approx. 105 kg

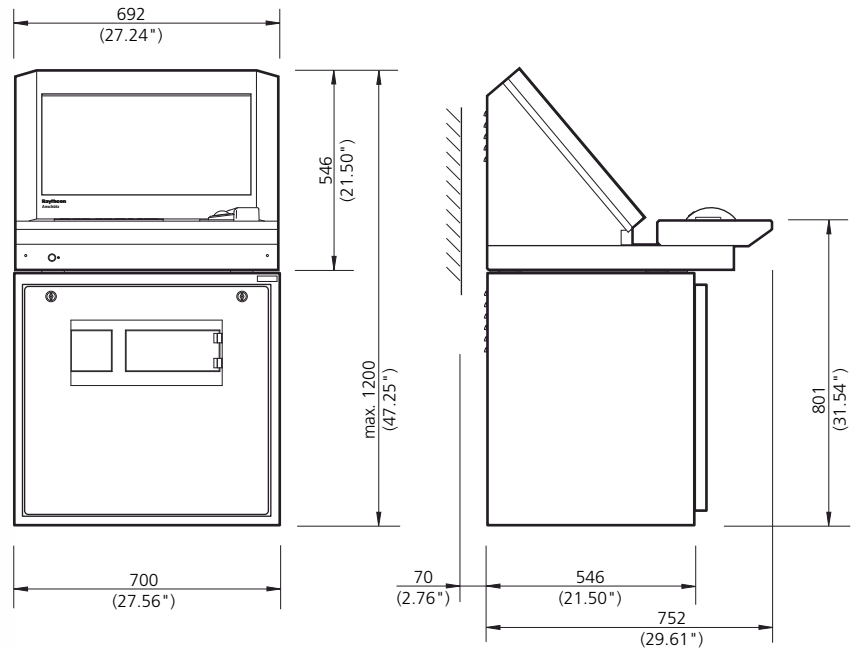

ECDIS computer 7 kg

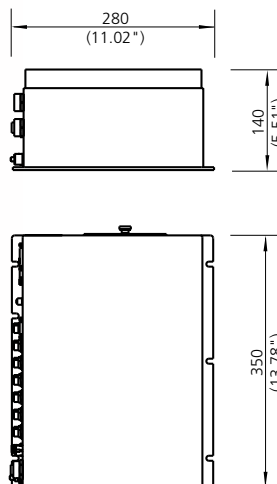

ECDIS operator panel

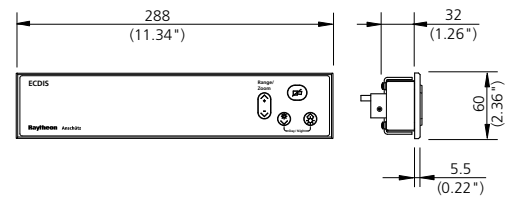

Trackball

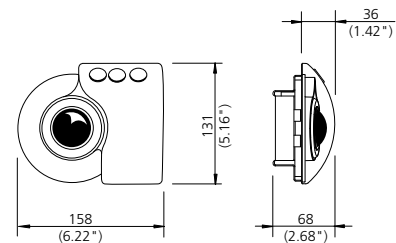

Registered trademarks

Intel™, INTEL Corp.
Windows 2000™, Windows XP™SP3,
Microsoft Corporation
NautoPilot® Raytheon Anschutz GmbH